



**INSTRUMENT  
TRANSFORMERS**



**FALCO**

# APPLICATIONS

## BUSHING CURRENT TRANSFORMER

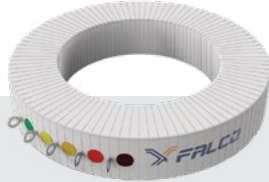
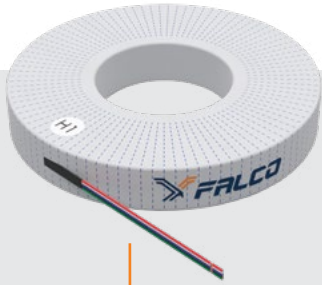

Power Distribution Transformer



HV Circuit Breaker

## WINDOW-TYPE CURRENT TRANSFORMER



MV Circuit Breaker

## GENERATION



Central Power Plant

## HIGH VOLTAGE



Substation

**HIGH-ACCURACY  
CURRENT TRANSFORMER**



**INSTRUMENT LOW VOLTAGE  
TRANSFORMER**



MV Switchgear



Pad Mounted  
Transformer



LV Switchgear

**MEDIUM VOLTAGE**

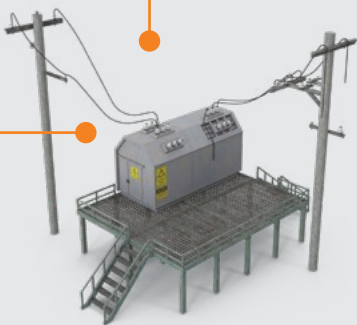

HV poles,  
MV Poles,  
Pad-Mounted  
Transformer

**LOW VOLTAGE**



Industrial Area



Residential &  
Commercial Area

# PRODUCTS

## Window-Type Current Transformer

Window-Type Current Transformers (CTs) provide a protected way to reduce the current for metering. Available in multiple sizes and aspects to suit a diverse array of applications. They ensure accurate, low-level outputs with negligible influence on the primary system.

Primarily used within switchgear, which consist of electrical disconnect switches, or circuit breakers designed to control, protect, and isolate electrical equipment. They enable safe de-energization for maintenance and facilitate fault clearing downstream.

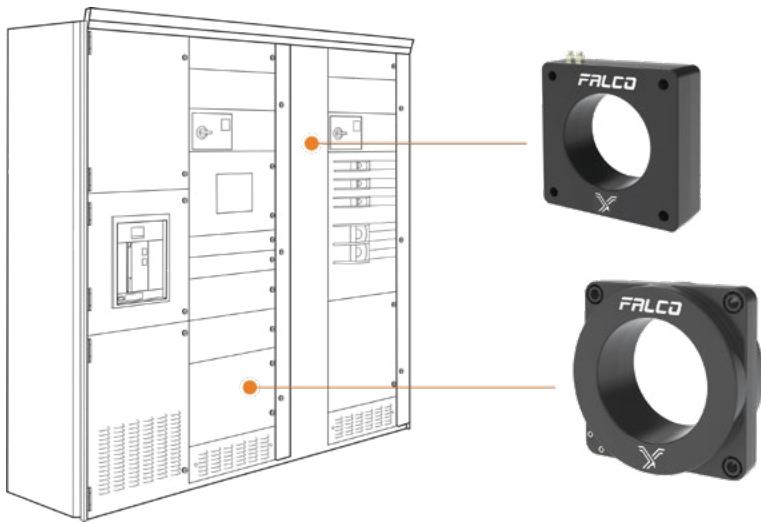

### OVERVIEW

- Primary Current: 50 to 6000Amp
- Secondary Current: 1A, 5A or customized
- Relaying Class: up to C800 (or 5P20, 200VA)
- Metering Class: down to 0.3 (or 0.2 for IEC)
- Rating Factor: up to 2.0 @ 30°C
- Basic Insulation level: 10kV
- Voltage Class: 600-720V
- Frequency: 50-400Hz
- IEEE C57.13, IEC 61869 compliant
- UL & CSA approved
- Encapsulated in plastic housing
- Available with single and multiple ratio secondary

## Ground Fault Sensor

A ground fault sensor, commonly referred to as a zero-sequence current transformer, detects ground faults by measuring the vector sum of currents in all the phases and neutral conductors. Any imbalance produces a detectable zero-sequence current which is indicative of a ground fault.

These CTs are typically installed around the neutral conductor of a three-phase system or around all three phase conductors (plus the neutral, if applicable).

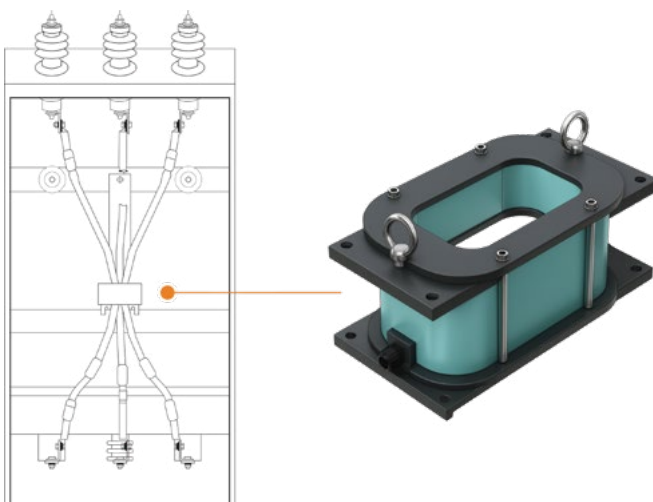

### OVERVIEW

- Primary Current: up to 1000Amp
- Secondary Current: 1A, 5A or customized
- Relaying Class: up to C200 (or 10P20, 50VA)
- Short-time thermal current: up to 25kA (3s)
- Voltage Class: 600-720V
- Frequency: 50-60Hz
- IEEE C57.13, IEC 61869 compliant
- Large rectangular window (up to 25in of length)

## High-Accuracy Current Transformers

High Accuracy CTs for industrial control applications ensure an exceptionally accurate signal transformation with low phase shift of less than  $0.1^\circ$  and high precision of 0.15% in amplitude transformation. Higher precision is achieved by using either nanocrystalline or amorphous core materials.

High Accuracy CTs are widely used in Power Distribution Units (PDUs), circuit breakers, Uninterruptible Power Supplies (UPS), and Watt-Hour Metering applications. They are commonly found in commercial and industrial facilities, with CTs typically housed within wall-mounted enclosures or meter sockets.

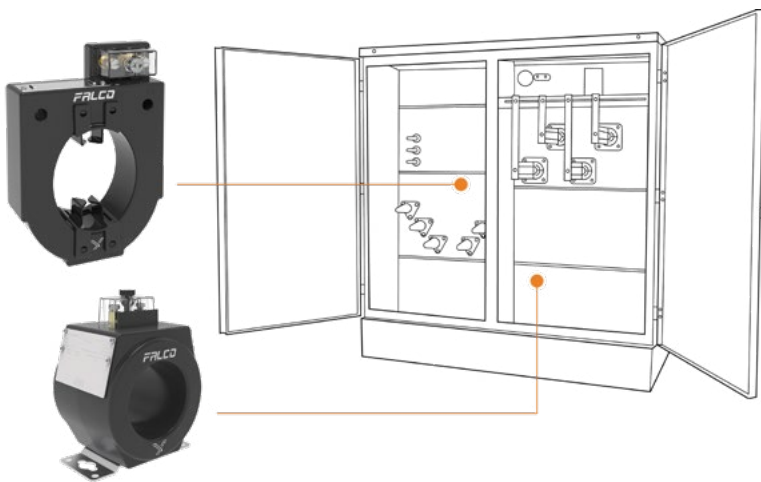

### OVERVIEW

- Voltage Class: 600-720V
- From 400A up to 1000A, ICT40 Series
- From 500A up to 4000A, ICHS36 Series
- 5 Amp rated current on the secondary side or customized
- Accuracy: 0.15S per IEEE C57.13-6 / 0.2S IEC 61869-2
- Ambient temperature up to 85°C and altitudes of 5000m on request
- All units are designed, manufactured, and tested to meet 0.15S or 0.20S accuracy from 0.5% of rated current up to the determined Rating Factor (Extended-Range)

## Instrument Low Voltage Transformers

Instrument Voltage Transformers (VTs) or Potential Transformer (PT), are high-accuracy electrical devices that reduces the voltage to level needed by the protective relays and metering devices.

Voltage Transformer are typically found in commercial and industrial installations such as Switchgears. VTs have their primary winding connected to the powerline and secondary windings to the measuring instrument. Installation is connected in parallel with the primary line.

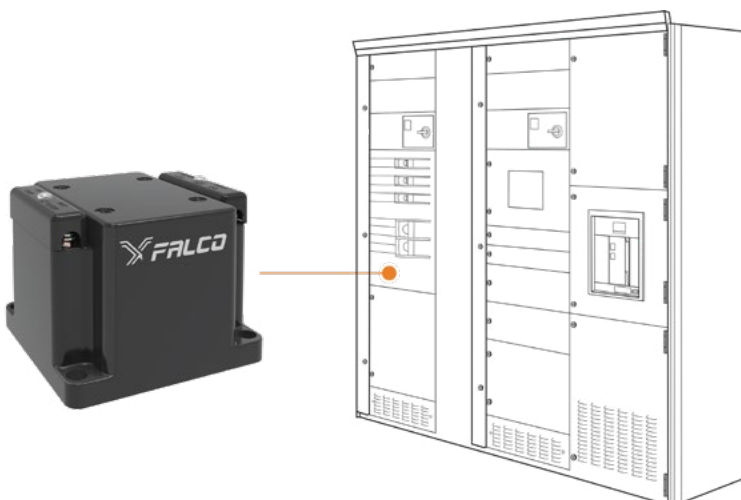

### OVERVIEW

- Primary Voltage: 69.3V to 600V
- Secondary Voltage: 120V
- Accuracy Class: 1.2X, 0.6W at 60Hz
- Thermal Rating: 150 VA AT 30°C. AMB, 100 VA AT 55°C. AMB
- Applicable Standard: ANSI IEEE C57.13
- UL & CSA approved
- Provided with two plastic terminal covers to ensure safety.

# PRODUCTS

## Bushing Current Transformers

Bushing Current Transformer is specifically designed to be mounted around a transformer bushing. They offer versatile applications in electrical systems due to their design and functionality, allowing for use in diverse environments and applications.

The selection of construction materials is dictated by the insulation methodology employed, with designs tailored for either air-insulated or oil-insulated configurations.

Bushing CTs are used in Dead Tank Circuit Breakers gas or oil insulated.

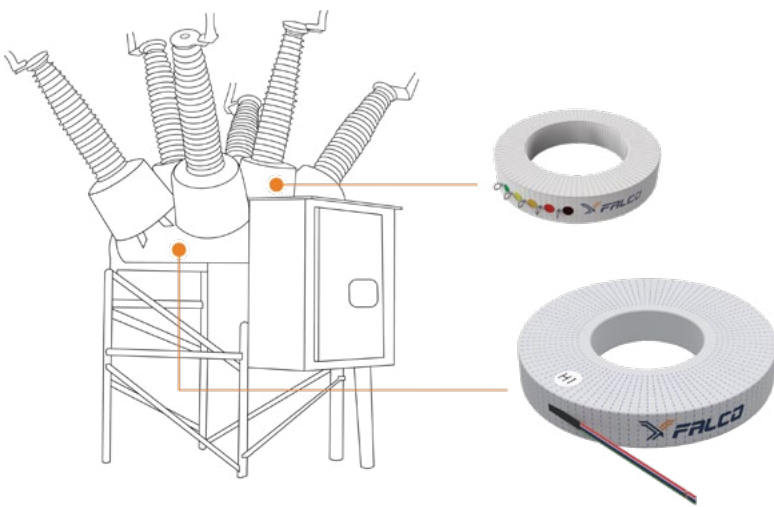

### Construction & Design

Bushing Current Transformers are constructed with a toroidal core and a uniformly distributed secondary winding.

Insulation material employed is either PET film rated 105°C (dry type) or a combination of kraft paper and cotton tape well suited for oil compatibility (oil type).

Core materials include grain-oriented silicon steel for standard applications, with nanocrystalline cores available for high-accuracy requirements.

Secondary winding is done with enameled copper wire, rated up to 200C and proven to be oil resistant.

### Terminations & Marking

Dry-type units are typically fitted with M6 ring tongue terminals or PVC/THHN lead wires, while Oil-type units are supplied with FEP or ETFE lead wires rated for higher temperatures and compatible with oil immersion.

Each transformer includes a durable polyester serialized nameplate listing key specifications for full traceability.

If required, a stainless-steel copy of the nameplate can also be provided.

### OVERVIEW

- AC Capability: 50 to 5000Amp
- Frequency: 50-60Hz
- Insulation Class: 0.6-0.72kV
- Applicable Standards: IEEE C57.13 & IEC61869
- Short-time thermal current ( $I_{TH}$ ) rated  $35 \times I_{DN}$  at 3s
- Short-time mechanical current ( $I_{DM}$ ) rated  $2.5 \times I_{TH}$

### DESIGN CAPABILITIES

- Inner Diameter: 3.0" [76mm] to 25" [635mm]
- Outer Diameter: 4.0" [100mm] to 35" [889mm]
- Relaying Class: up to C1200 per IEEE C57.13; up to 5P20 at 300VA per IEC61869
- Metering Class: down to 0.15S per IEEE C57.13; down to 0.2S per IEC61869
- Operating Temperature: -20°C to 55°C (Dry Type); -20°C to 95°C (Oil Type)
- Rating Factor: up to 4.0 @ 55°C (Dry Type); up to 2.0 @ 95°C (Oil type)

### OTHER FEATURES

- Single ratio, dual ratio, multi ratio
- Non standard ratings available
- Customized test reports
- Accuracy class PX per IEC61869
- Laser engraved stainless steel Nameplates

### Packaging & Shipping

To ensure safe delivery, every transformer is packed in sealed wooden crates that protect against moisture and handling. Returnable plastic containers are also available as a sustainable packaging alternative.

# CAPABILITIES

## Core Production

- High-grade silicon steel – M3 to M6
- Up to 650mm diameter
- Rectangular and elliptical geometries

## Core Annealing

- Vacuum annealing process
- 1.5 tons per cycle



## Plastic Injection Molding

- Thermoplastic material
- Up to 13" wide
- Consistent quality



## Winding

- 6 AWG (4.25mm) to 32 AWG (0.22mm)
- Cores from 1.6" to 32"
- Rectangular and elliptical up to 12" wide

## Testing & Verification

- IEEE, IEC and CSA standards
- Certified Test reports
- Traceability

# WORLDWIDE MANUFACTURING FACILITIES

## MEXICO

MERIDA - YUCATAN

## CHINA

XIAMEN - FUJIAN

## INDIA

BENGALURU - KARNATAKA



Ph +39 (039) 928 5507 Ext 2182



europesales@falco.com

[www.falco.com](http://www.falco.com)

